

# User Manual

## CPAM

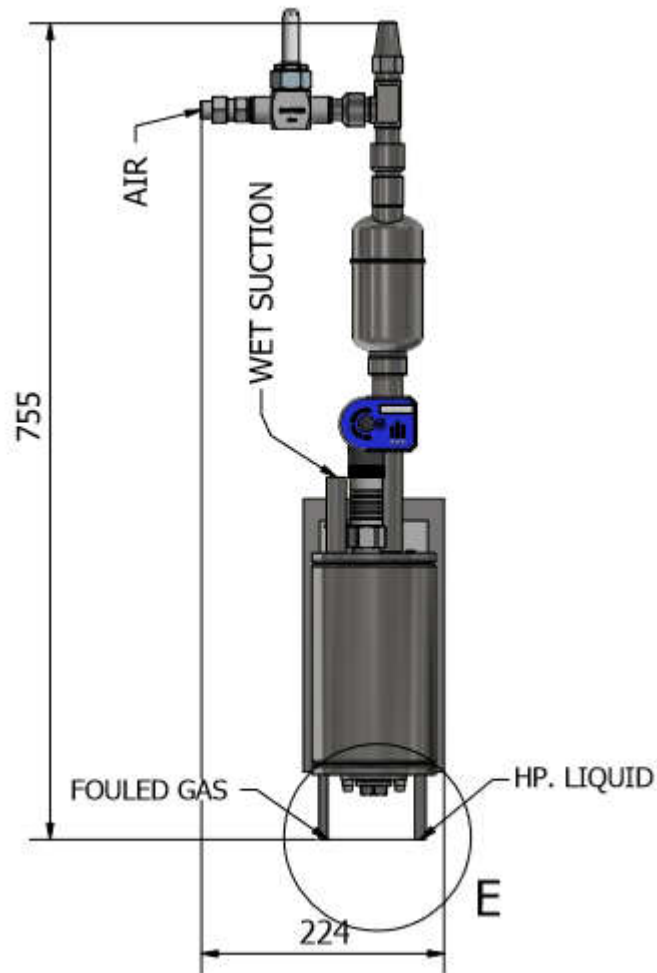

## Index

|       |  |
|-------|--|
| 1     | Introduction and description                             |
| 2     | System type  |
| 2.1   | Technical specifications                                 |
| 2.2   | The intended use of the system                           |
| 3     | Safety information                                       |
| 3.1   | Use of the operating instructions and other instructions |
| 4     | Users  |
| 4.1   | Requirements for users                                   |
| 5     | Compliance with  |
| 6     | Installation   |
| 6.1   | Description of the system                                |
| 6.2   | Assembly and installation                                |
| 6.2.1 | Fixation   |
| 7     | Commissioning  |
| 7.1   | Before commissioning                                     |
| 8     | Operation of the system                                  |
| 9     | Further information                                      |
| 10    | PID & drawings   |

## 1 Introduction and description

CPAM is a mini air purger for small Industrial ammonia refrigeration systems and all sizes industrial ammonia chiller units.

### Air purging function:

Fouled ammonia gas from the purge points is lead to the air purger, where the the ammonia gas is condensed in a coil. The condensed ammonia liquid with its contend of non-condensable gas (air) is lead to an inner chamber, where the liquid is drained out from the bottom through an orifice system to the low pressure side and the non- condensable gas (air) is trapped over the liquid. When the special liquid level sensor detects a low liquid level at a factory pre-adjusted set point, it gives a digital signal to open the air out-blow solenoid valve with an orifice mounted in the valve. When the liquid level rises to the upper factory pre-adjusted set point a digital signal will close the air out-blow solenoid valve again. The purged air passes through an air vent liquid trap securing no ammonia liquid is able to pass with the purged air in case of electrical fault, installation error or misuse should occur.

## 2 System type

The system is equipped with name plates:

|                               |                             |  |
|-------------------------------|-----------------------------|--|
| <b>Ammonia AIR PURGER</b>     | Baujahr/Built: xxxx         | <br>Cool Products ApS<br>Bøgekildevej 21<br>DK-8361 Has selager<br>CE |
| TYPE: <b>CPAM</b>             | Serien-Nr/Seriel-No: xxxxxx |  |
| Medium/Fluid: <b>NH3/R717</b> | TS: <b>-50°C / +50°C</b>    |  |
| Inhalt/Volume: <b>1,9 L</b>   | PS: <b>25 bar</b>           |  |
| Leergew./Weight: <b>6 kg</b>  | PT: <b>36 bar</b>           |  |

## 2.1 Technical specifications:

Air purger nominal ammonia capacity: approx. 2 kW

Air purgers nominal air purging capacity in liter pr. minute, when air is purged at different condensing pressures, see below:

| Condensing pressure in temperature °C | Volume of purged air at condensing pressure<br>Approx. Liter / minute | Volume of purged air at atmospheric pressure<br>Approx. Liter/minute |
|---------------------------------------|---|--|
| 10                                    | 1.31  | 11.9   |
| 15                                    | 1.32  | 14.0   |
| 20                                    | 1.33  | 16.3   |
| 25                                    | 1.33  | 18.9   |
| 30                                    | 1.34  | 21.7   |
| 35                                    | 1.35  | 24.9   |
| 40                                    | 1.36  | 28.3   |
| 45                                    | 1.36  | 32.1   |
| 50                                    | 1.37  | 36.2   |

## 2.2 The intended use of the system

The plant may only be used according to documentation. It is expected that the plant will be used in accordance with Cool Product's instructions. Special care must be taken following the instructions that have a safety significance.

### 3 Safety information

Read these instructions carefully before installing, operating, maintaining or inspecting the system. In this manual, a number of pictograms for safe operation are classified as "Warning" or "Information" as shown below.

This instruction provides a brief overview of the most important safety conditions when setting up, maintaining and using the equipment. Attention is drawn to the fact that it is the responsibility of the end user that the entire plant is maintained and inspected according to the regulations for the individual installation parts (see Operation & Maintenance Manual).

Use that violates the instructions contained in this manual and which causes injury to persons, animals and equipment, voids any warranty from Cool Products.

Modifications to the equipment that affect the safety of the equipment are not permitted. Before using the equipment, check that the equipment is undamaged and installed as directed by Cool Products.

Attention is especially drawn to:

- National safety rules
- National health and safety requirements at work
- National installation rules for the type of installation concerned
- Recognized standards
- The safety information in this guide
- Data and information about permissible installation and operating conditions on the equipment label plate
- Instructions for and any type certificates for equipment installed on the plant.

**Failure to follow these instructions can result in loss of warranty on the system!**

#### 3.1 Use of the operating instructions and other instructions

- It is the responsibility of the owner to maintain the system, so that it meets the requirements in relation to the installation of refrigeration systems at all times.
- The operating instructions and associated instructions, plans and other documentation provided are considered as part of the installation.
- Operating instructions, etc. must be stored, maintained and updated throughout the life of the plant.
- The operating instructions should be stored at the plant.
- If the unit is transferred to another owner or user, the user manual must be transferred with the unit.

### 4 Users

The plant may only be used, serviced and repaired by instructed / trained personnel, who are at least 18 years of age.

## 4.1 Requirements for users



| Users                   | Description of education level  |
|-------------------------|---|
| Assembly or disassembly | <p>Persons who carry out assembly or disassembly must read and understand the operating instructions for this area, as well as the information available at the plant.</p> <p>The person must also be in possession of the necessary professional education for the area in question.</p> |
| Service / Maintenance   | <p>Persons who carry out Service / Maintenance must read and understand the operating instructions for this area, as well as the information available at the plant.</p> <p>The person must also be in possession of the necessary professional education for the area in question.</p>   |
|                         |   |

## 5 Compliance with

This system complies with the following directives:

- PED

Declarations of Conformity for this system are found in the supplied documentation.

## 6 Installation

### 6.1 Description of the system

P&I diagram of CPAM with pos. no.

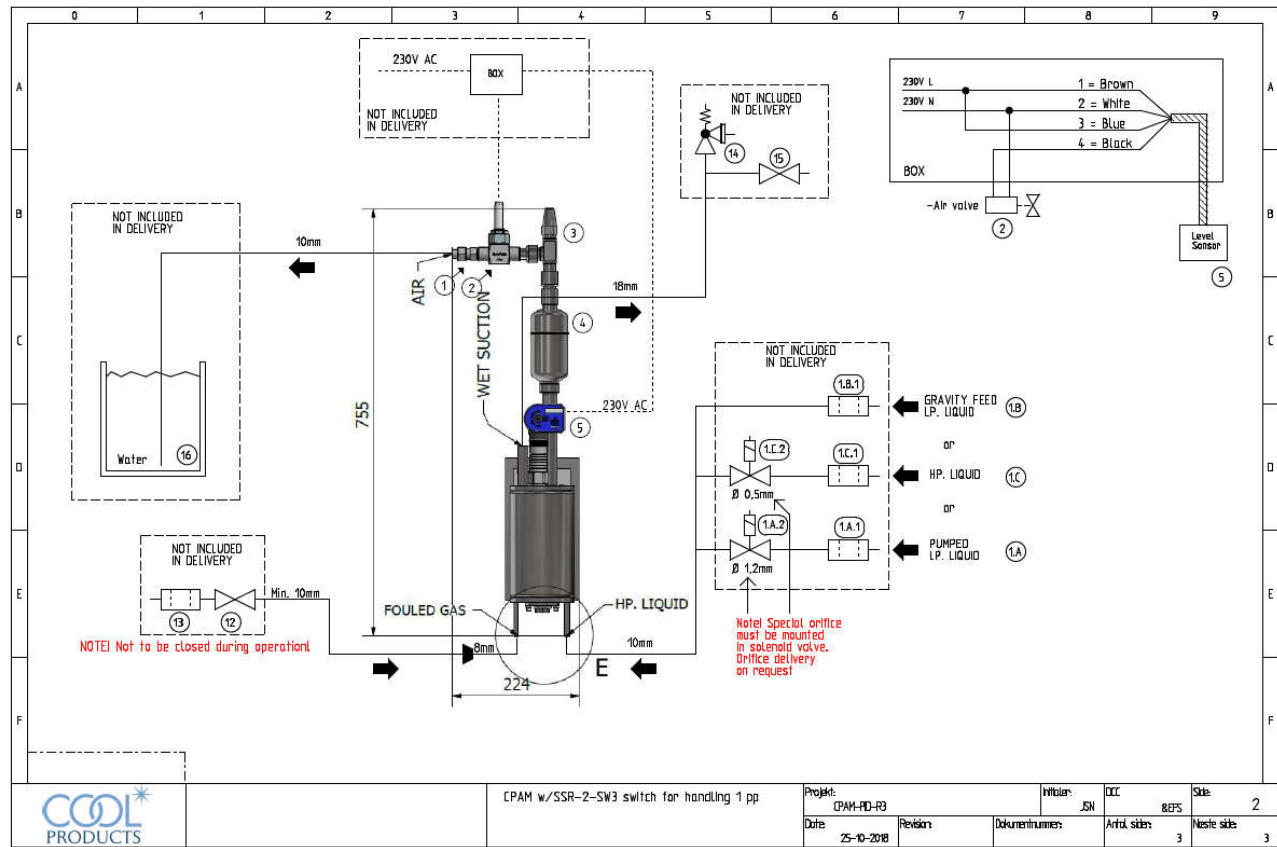
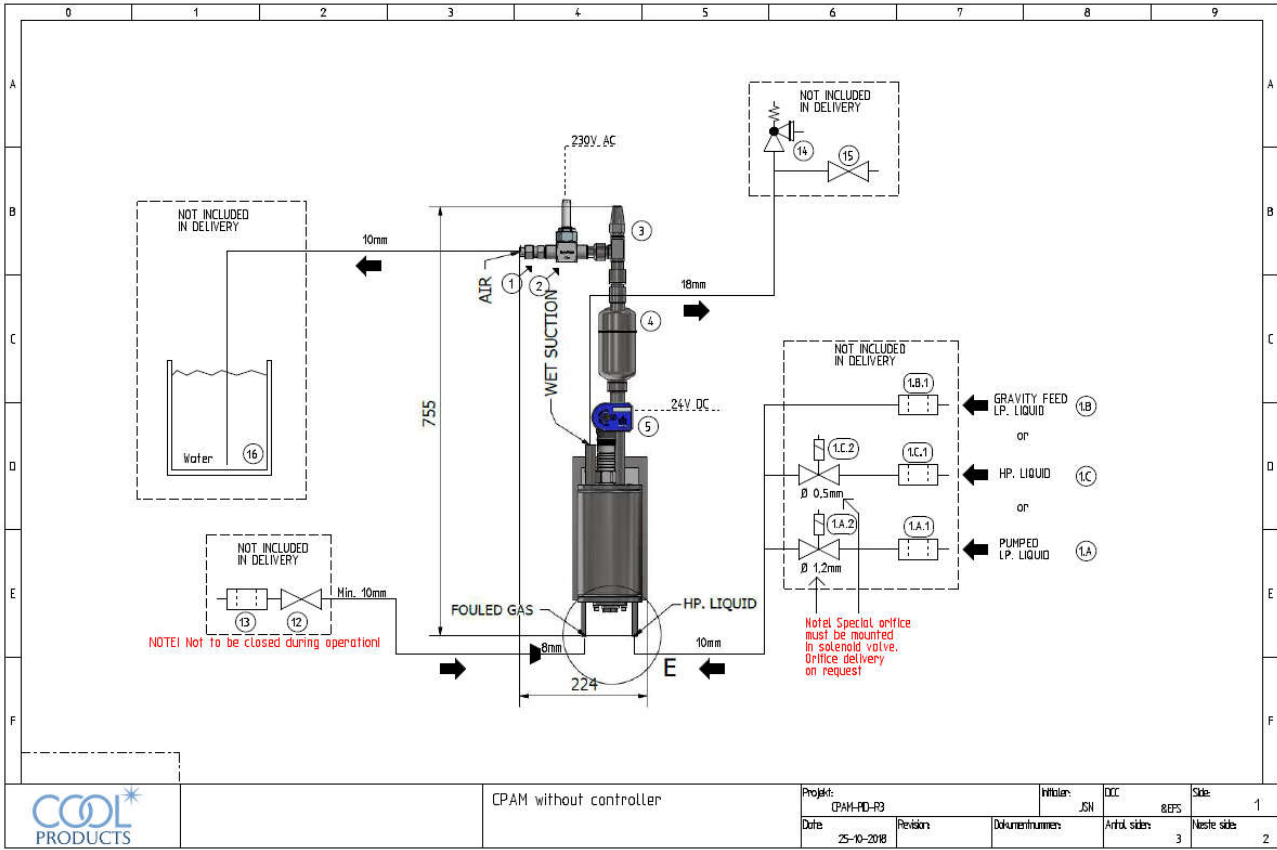

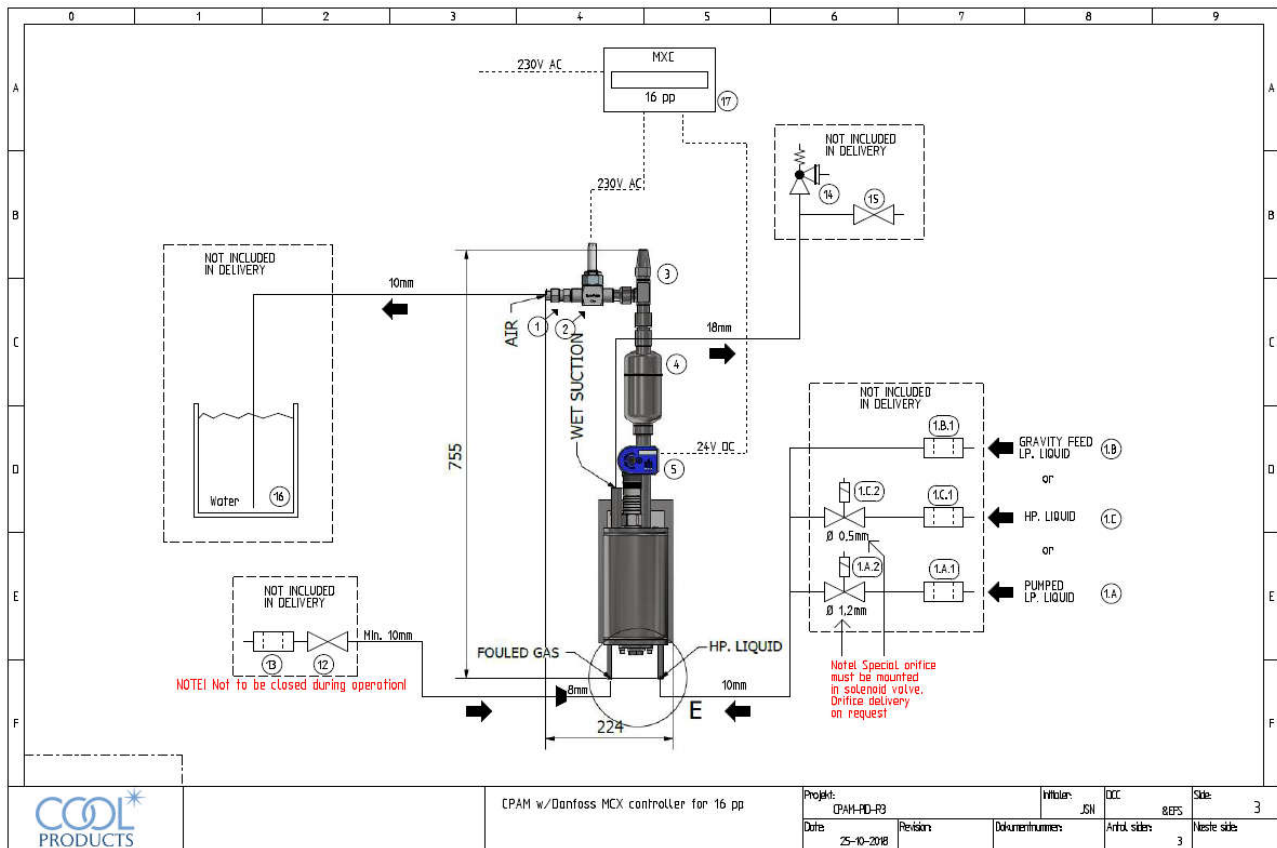

Pos. No. explanation:

- 1) Check valve
- 1.C.2) Special orifice  $\varnothing$  0,5 mm for service with HP liquid supply. INCLUDED IN DELIVERY.
- 1.A.2) Special orifice  $\varnothing$  1,2 mm for service with pumped LP liquid. INCLUDED IN DELIVERY.
- On gravity liquid feed systems there must NOT be any orifice. The correct size orifice for the application must be mounted before the gas unit is put into operation.
- 1.A.1 / 1.B.1 / 1.C.1) Filter. NOT INCLUDED IN DELIVERY. Filter must be mounted to ensure the very small orifices in the CPAM is not clogged.
- 2) EVM solenoid valve with special orifice mounted
- 3) Service stop valve
- 4) Air vent liquid trap
- 5) Special factory calibrated liquid level sensor with preset digital set points
- 12) Service stop valve. NOT INCLUDED IN DELEVERY. NOTE: Must never be closed during normal operation as this can lead to unintended release of ammonia gas through the air put blow system.
- 13) Filter. NOT INCLUDED IN DELIVERY. Filter must be mounted to ensure the very small orifices in the CPAM is not clogged.
- 14) Safety valve. NOT INCLUDED IN DELIVERY. Must be mounted according to local rules and regulations.
- 15) Service stop valve. NOT INCLUDED IN DELIVERY.



16) **Water filled reservoir.** NOT INCLUDED IN DELIVERY.

**Function:** Absorption of any ammonia gas that might be purged with the air (non-condensable gas). Bubbles that pass through the water to the surface are air (non-condensable gas), while bubbles that disappear in the water will be ammonia gas.

**Note:** The ammonia content in the purged air will depend on the difference between the saturated condensing and saturated evaporating temperatures respectively. A large difference will result in a very low content of ammonia, while a low difference will result in a somewhat higher content.

## 6.2 Assembly and installation

### Installation environment

The area where the equipment is installed must be chosen or arranged so the parts of the plant are not unnecessarily exposed to mechanical impacts from the surrounding area, which can cause damage to the equipment, especially the electrical parts of the system.

### Ambient temperature

To ensure compliance with the equipment's temperature (TS), the ambient temperature range interval (indicated on the name plate) must not be exceeded. Therefore, when installing the system, it is necessary to consider any external heat sources that could affect the ambient temperature in the area, where the equipment is installed.

### Assembly and disassembly

The equipment must be assembled as indicated in drawings provided by Cool Products (see the supplied drawings). This also applies when replacing spare parts. It is not permitted to use spare parts that are not approved / directed by Cool Products, as this may affect the safety of the system.

### 6.2.1 Fixation

The foundations and anchoring points to which the system is attached must be able to withstand the physical conditions to which the plant can be exposed, including;

- The weight of the installations
- Impacts / loads during use
- Vibrations
- Heat dissipation Conditions

## 7 Commissioning

### 7.1 Before commissioning



Before commissioning, make sure that the following are correctly performed:

- Leak test
- Electrical function test

## 8 Operation of the system

When the CPAM is powered on, it requires a timer delay so the air out-blow solenoid valve can't open the first 10 to 30 minutes (depending on timer setting) to ensure the pressure is high and the temperature is so low inside that ammonia gas in the inner chamber is condensed.

**Attention: the differential pressure of the plant has to be minimum 15K before starting the air purger**

The fouled gas line from the purge points must never be closed while the CPAM is operating, as this can lead to unintended release of ammonia gas through the air out-blow connection.

When the air purger is filled with non-condensable gas the liquid level sensor will open the air out blow connection and release air until liquid level is high and close the air out-blow connection again.

### Air purger:

- The parts which can be serviced on the air purger are:
- The orifice in the bottom of the solenoid valve (pos. 2) in the air out-blow line
- The orifice (pos. 1.A.2 and 1.C.2) mounted in the liquid supply line, if it's a pumped LP or HP liquid line.
- The internal filter and orifice mounted in the bottom plug on the air purger.

Servicing the build in filter and orifice in the bottom plug see drawing below:

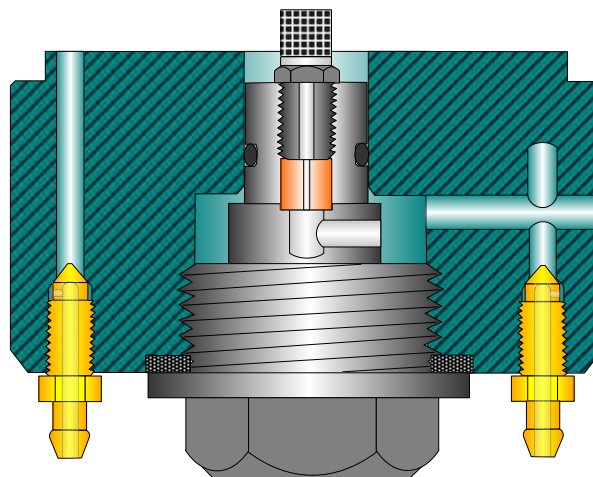

First all connections to the refrigeration system must be closed off.

Note: wear protective glasses, gas mask and gloves when evacuating the ammonia from the CPAM.

The ammonia pressure can be evacuated from both the air purger vessel and the inner chamber by fitting a small hose to each of the small pressure bleed screws mounted beside the bottom plug. **Carefully loosen these two bleed screws** and the ammonia gas and liquid can be carefully drained off the air purging unit.

After evacuating the ammonia and securing no over pressure is present, the bottom plug can be unscrewed and the build in filter and orifice (see drawing above) can be dismantled and cleaned.

After cleaning filter and orifice, the bottom plug with orifice and filter is mounted, the two bleed screws securely fastened and the unit can be opened to the refrigeration system and put back into operation.

Repair, service and maintenance must be done in accordance with the instructions of Cool Products and must be carried out by personnel who possess the necessary qualifications in relation to the handling of the equipment.

Particular attention must be paid to the mechanical parts;

- Lifetime of wearing parts
- Damage to mechanical parts
- Corrosion on mechanical parts
- Tightening of bolts, screws

## 9 Further information

For further information about the system, please contact Cool Products

# 10 PID & drawings

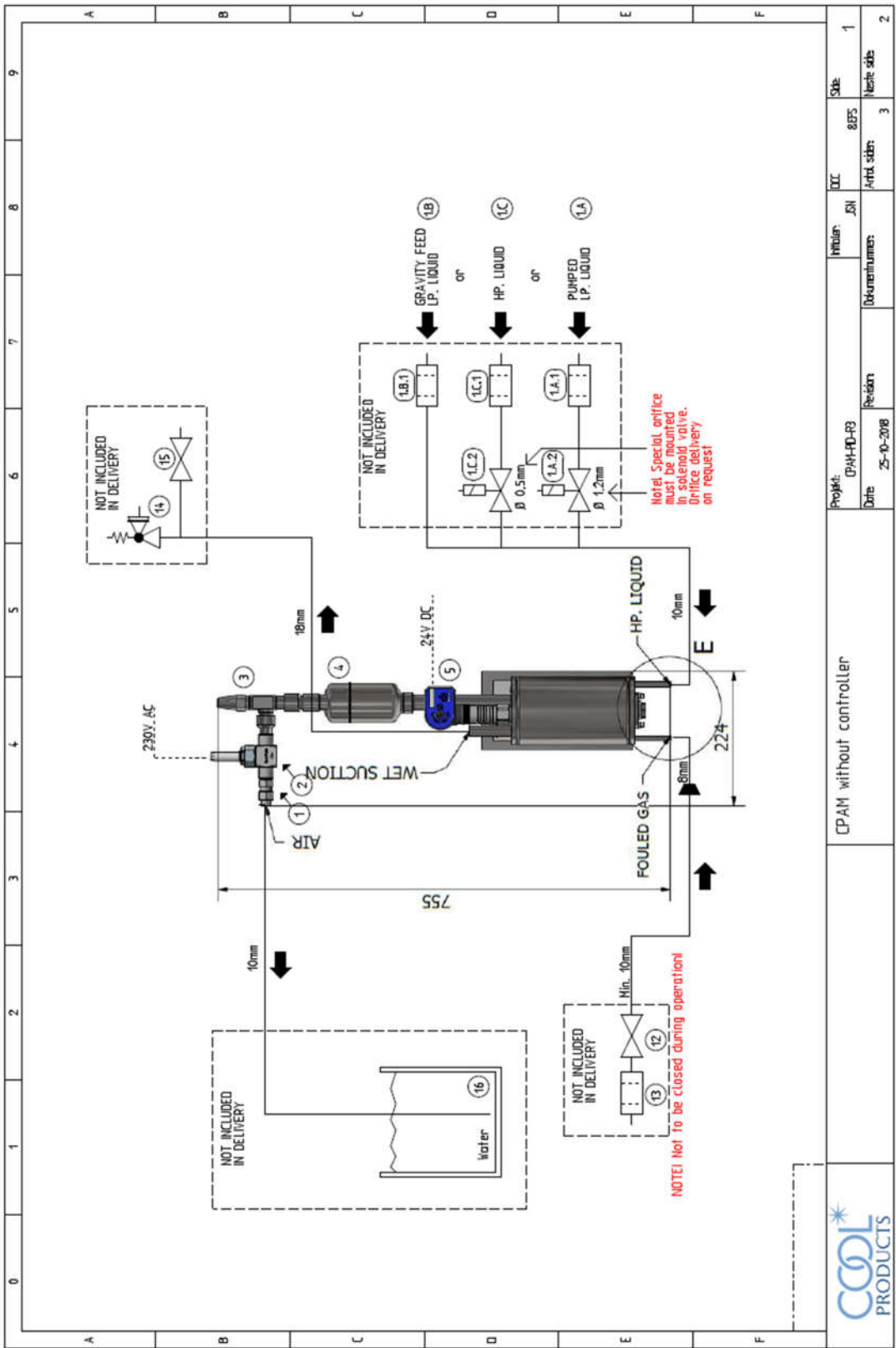

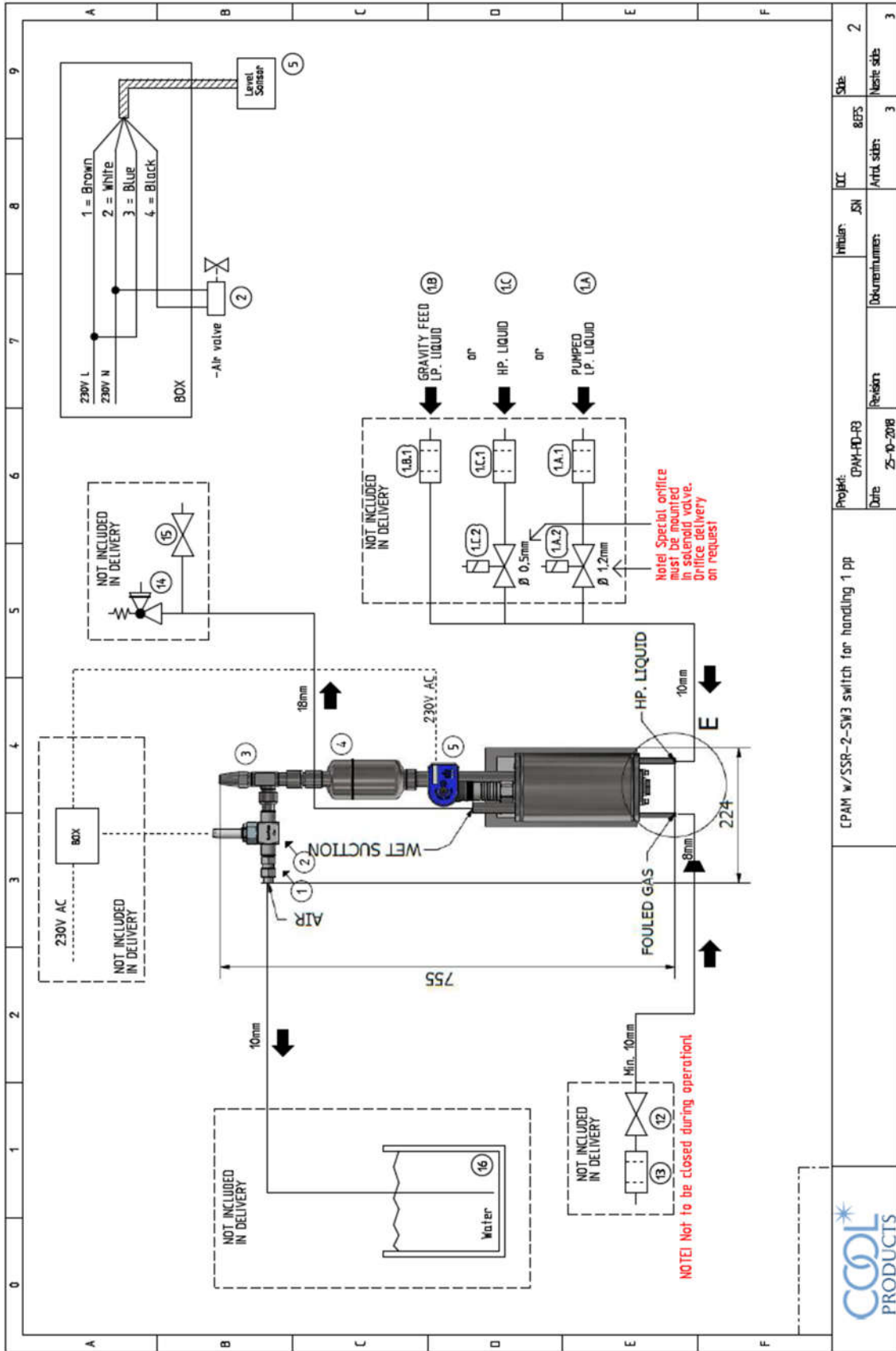

|   |                     |             |                |               |
|---|---------------------|-------------|----------------|---------------|
| CPAM w/SSR-2-SW3 switch for handling 1 pp | Projekt: CPAM-PP-R3 | Immun: SN   | DIC: 8EFS      | Sub: 2        |
|   | Date: 25-10-2018    | Revisjon: 3 | Artdr. side: 3 | Neste side: 3 |



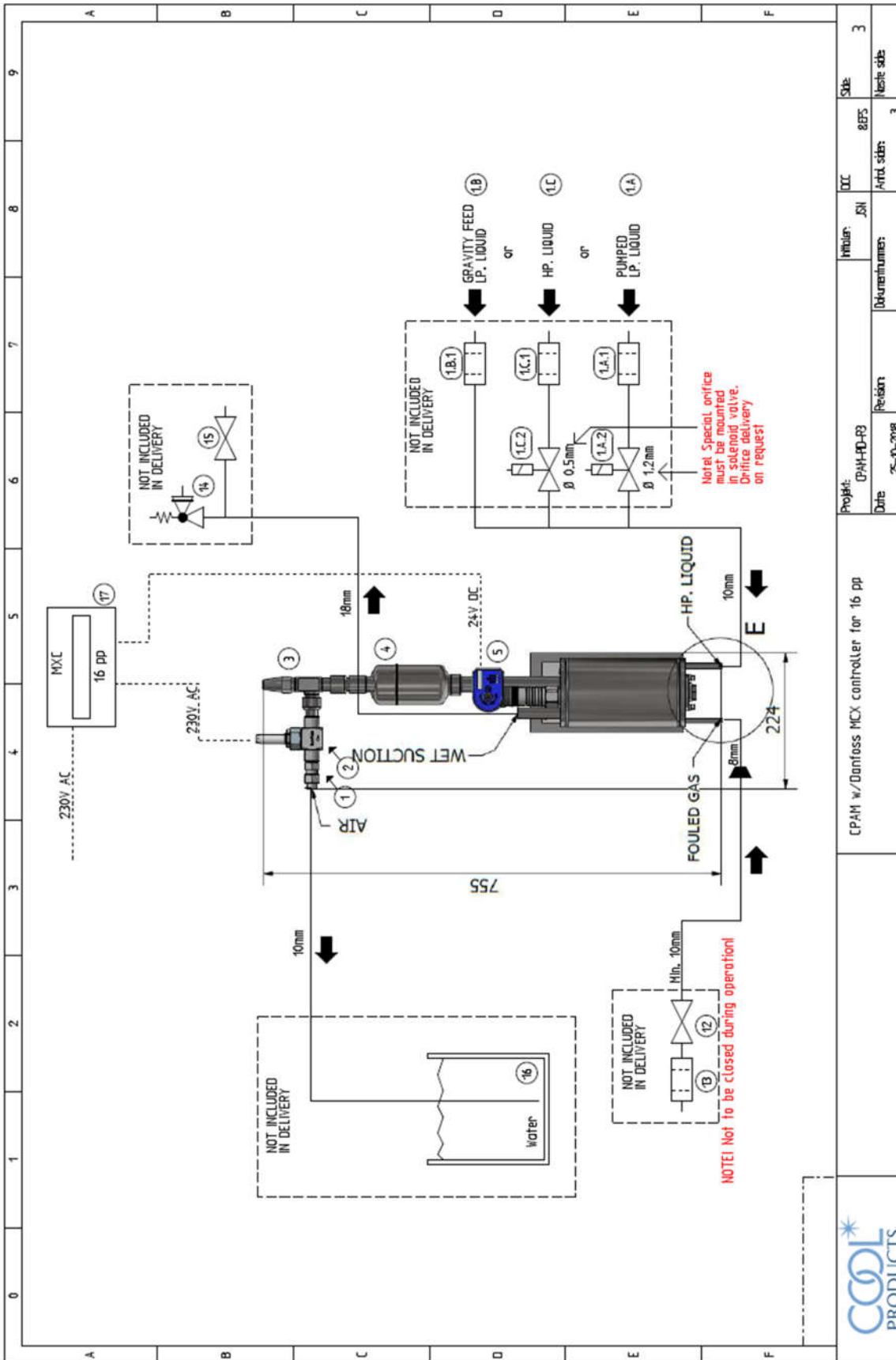

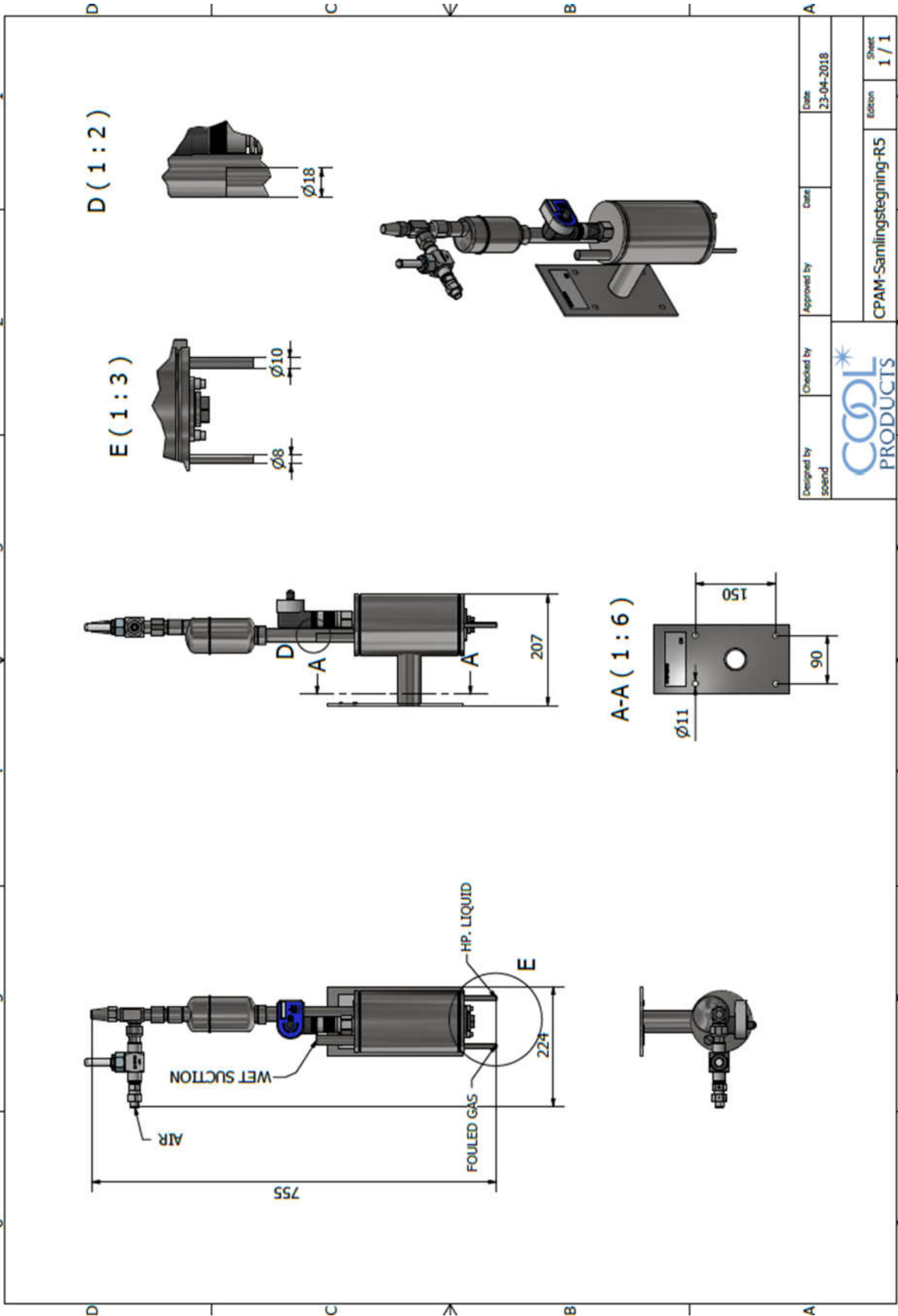

|                      |            |             |                         |                |
|----------------------|------------|-------------|-------------------------|----------------|
| Designed by<br>spand | Checked by | Approved by | Date<br>23-04-2018      | Sheet<br>1 / 1 |
| <b>COOL PRODUCTS</b> |            |             | CPAM-Samlingstegning-R5 |                |